

100
120
140

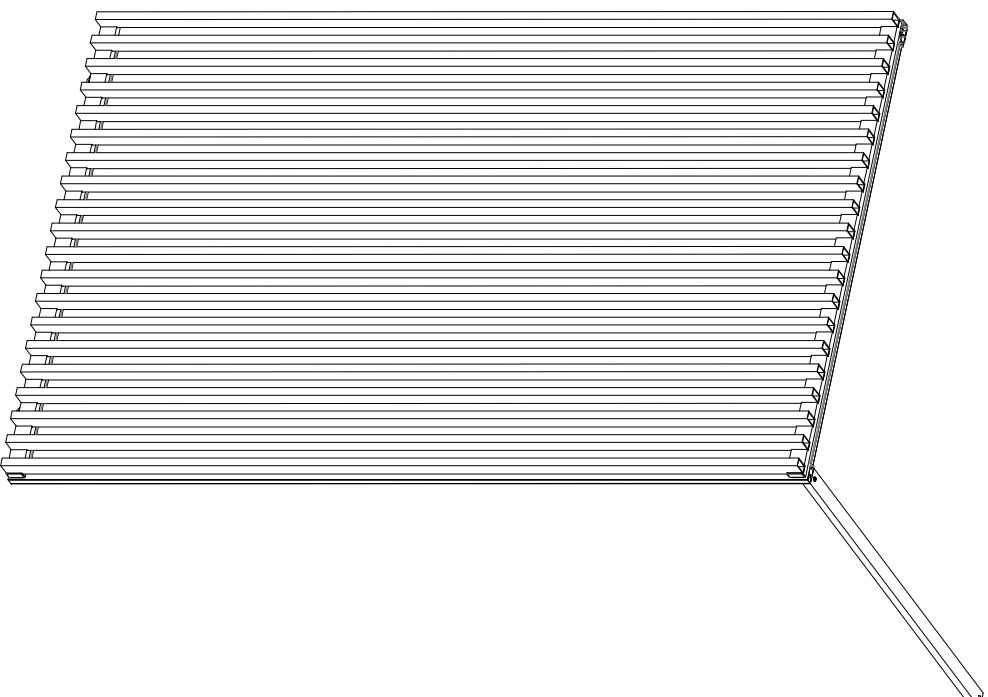

JACUZZI FRANCE
8, Route de Paris
BP 70203
03305 CUSSET CEDEX
FRANCE

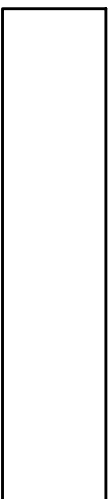

www.jacuzzi.fr - S.A.S. CAPITAL 1 410 159 € - R.C.S. CUSSET 399 788 043

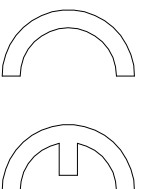

JACUZZI FRANCE
8, Route de Paris
BP 70203
03305 CUSSET CEDEX

20

EN 14428+A1



E096-B



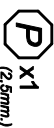
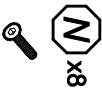
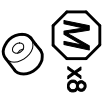
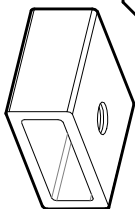
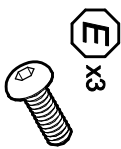
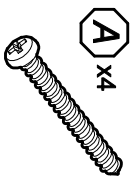
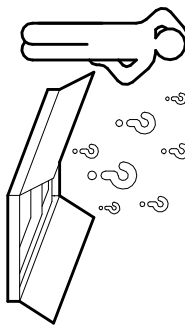
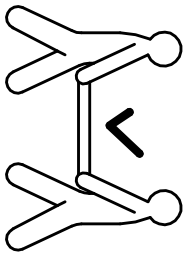
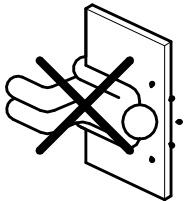

IMPORTANT ! DOCUMENT A CONSERVER

SERVICE CONTRÔLE QUALITÉ
GARANTIE 2 ANS

Le numéro ci-dessous définit avec précision le produit que vous venez d'acquérir. Sans ce numéro, il nous serait impossible de donner une suite favorable à votre réclamation. Conservez-le !

ENTRETIEN
Eau tiède savonneuse
Pas de détergent

F

*Notre production est garantie dans les conditions qui suivent, contre tous vices de fabrication et défauts d'aspect, conformément aux règles de l'art, à nos instructions de montage, aux normes et aux DTU en vigueur. L'application de la garantie n'a pas pour effet de prolonger sa durée. Notre garantie est limitée à l'échange de la (ou les) pièce(s) reconnue(s) ou responsable(s) du mauvais fonctionnement de l'appareil, par une pièce identique.

En aucun cas, il ne peut être réclamé, de frais de main d'œuvre, de frais de déplacement, ni aucun dommage et intérêt notamment pour privation de jouissance ou autre:

- accident(s) ou choc(s)
- utilisation de produits corrosifs ou abrasifs pour le nettoyage
- détérioration(s) par corps étrangers (sable, limaille,...) véhiculés par l'eau
- négligence(s), fausse(s) manoeuvre(s)
- dommage(s) occasionné(s) par la qualité de l'eau, notamment le calcaire
- et toute autre forme d'utilisation anormale. *

QUALITY CONTROL SERVICE
2 YEARS WARRANTY



UK

The number printed below here under uniquely identifies the product you have bought. Without this number we are not able to handle any after sales complaint.
Please keep it in safe place !

CLEANING
Hot soapy water
Not detergent !

*Our products are guaranteed in accordance with the following conditions: against defective material and/or workmanship, surface defects, in accordance with normal practice and in due compliance with our assembly instructions, standards and user's technical manual currently in force (DTU). Any guarantee claim shall not be deemed as extended the validity of our 2-year guarantee. Our guarantee is limited to the replacement, by an identical part (or parts) deemed as defective by our company, or parts causing malfunction of the equipment. In no circumstances whatsoever cost, travelling expenses and/or any liquidated damages be claimed, especially for :

- damage(s) and/or shock(s)
- utilisation or control of abrasive products for cleaning operations
- damage(s) caused by foreign bodies, sand, swarf,...
- négligence(s), false manoeuvre(s)
- damage(s) resulting from water quality (hard water especially)
- any improper utilisation. *

WICHTIG !

QUALITÄTSKONTROLLSERVICE 2 JAHRE GARANTIE

Die Nummer auf der Rückseite wurde dem Produkt zugeordnet, das Sie gekauft haben. Ohne diese Nummer sind wir nicht in der Lage, Reklamationen entgegenzunehmen und zu bearbeiten. Bitte bewahren Sie Nummer an einem sicheren Platz auf.

Pflege
Warme Seifenlauge
Keine scharfen
Reiniger !

D

*Unsere Produkte werden gemäß folgenden Bedingungen garantiert: Gegen Material- und Herstellungsfehler sowie Oberflächenfehler vorausgesetzt, dass der Einbau gemäß unseren Einbauanleitungen, gültigen Normen und den derzeit gültigen technischen Gebrauchsanleitungen erfolgt. Die Inanspruchnahme der Garantie bedeutet keine Verlängerung der Gültigkeit der Garantiezeit. Unsere Garantie beschränkt sich auf den Austausch des Teils, die von uns als defekt anerkannt wurden, oder des Teils, das für die Fehlfunktion verantwortlich ist. Unter keinen Umständen können Arbeitskosten, Reisekosten und/oder Schadenersatzansprüche geltend gemacht werden, insbesondere für :

- Unfall, oder Shock
- Verwendung von Sitzzanden oder schließenden Reinigungsprodukte
- Schaden durch Fremdkörper (Sand, Fallspäne...)
- Nachlässigkeit, falsche Handhabung
- Schaden durch Wasserqualität, besonders Kalk verunrsacht
- und jede unpassende Verwendung."

IMPORTANTE !

SERVICIO CONTROL CALIDAD GARANTIA 2 ANOS

El numero estipulado en dorso de esta garantía define con exactitud el producto que ha adquirido. Sin dicho numero, nos resultaría imposible atender su reclamación. Conserve!o !

Limpeza
Agua tibia y jabon
No detergente !

E

*Nuestros productos están garantizados bajo las siguientes condiciones, contra cualquier defecto de fabricación y de aspecto, con reserva de ser instalados por profesionales cualificados y según nuestras instrucciones de instalación y las normas vigentes (DTU). La aplicación de la garantía no tiene como efecto prorrogar su duración. Nuestra garantía está limitada al cambio de la (o las) pieza(s) reconocida(s) por nosotros como defectuosa(s) o responsale(s) del mal funcionamiento del aparato, por una(s) pieza(s) idéntica(s). En ningún caso, se podrán reclamar gastos de mano de obra, ni gastos de desplazamiento ni cualquier otro daño y perjuicio, particularmente por privación de goce u otro :

- accidente(s) o choque(s)
- utilización de productos corrosivos o abrasivos para la limpieza
- deterioro(s) por cuerpos ajenos (arena, limalla,...) vinculadas por el agua
- negligencia(s), mala(s) manipulación(es)
- daño(s) ocasionado(s) por la calidad del agua, particularmente la cal
- y cualquier otra forma de uso anormal."

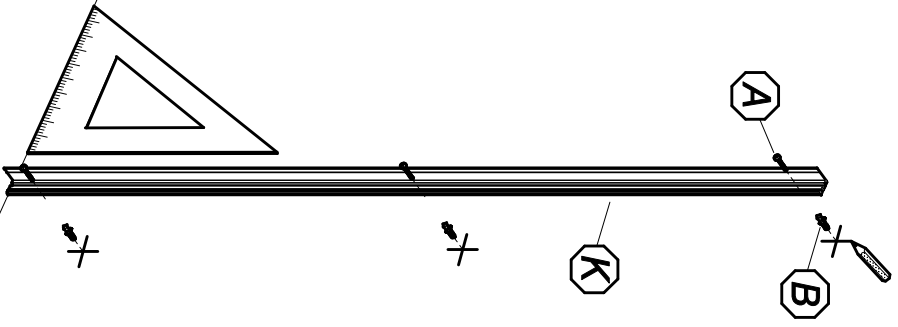

A large rectangular area filled with a grid of dotted lines, intended for writing or drawing.

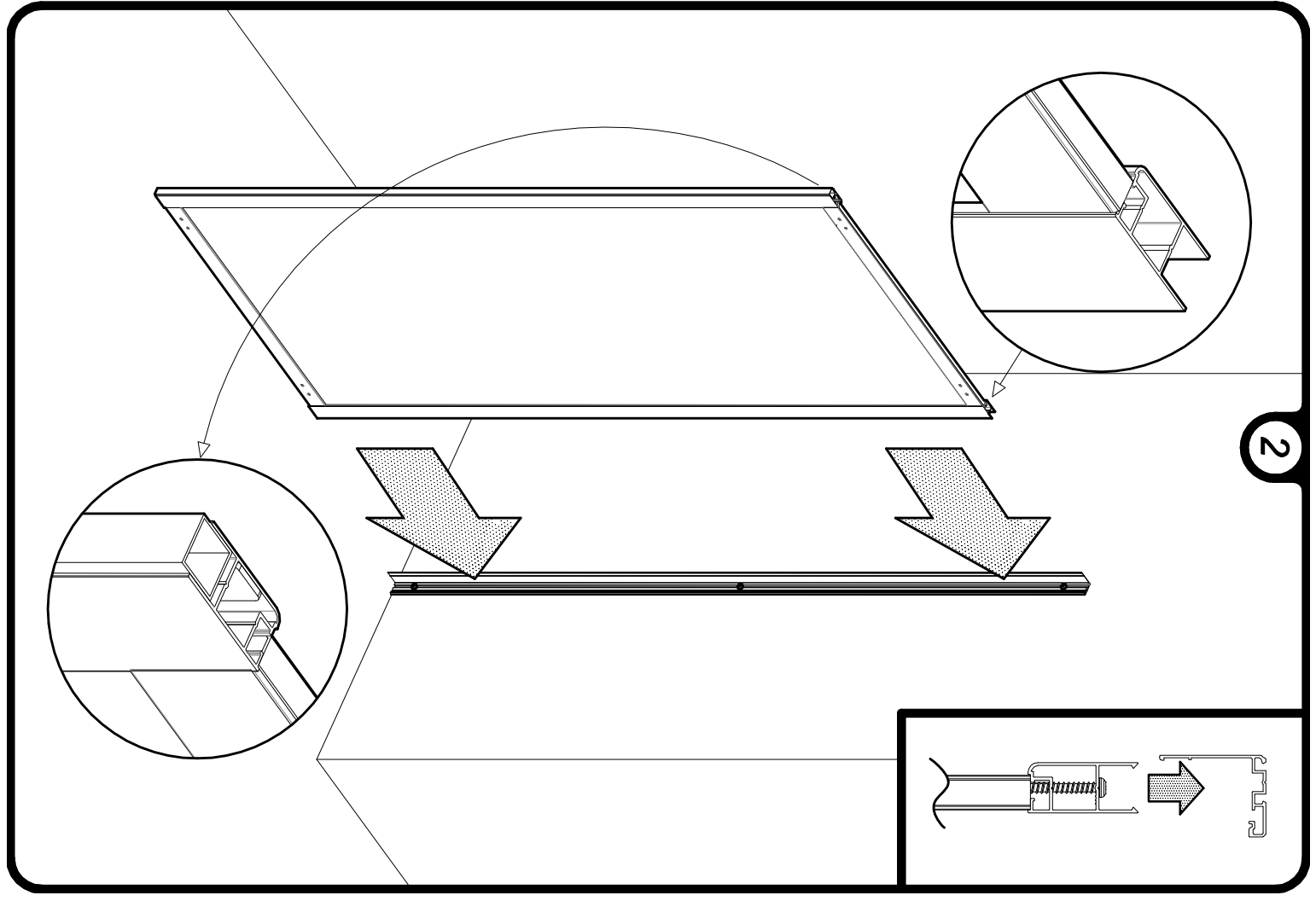
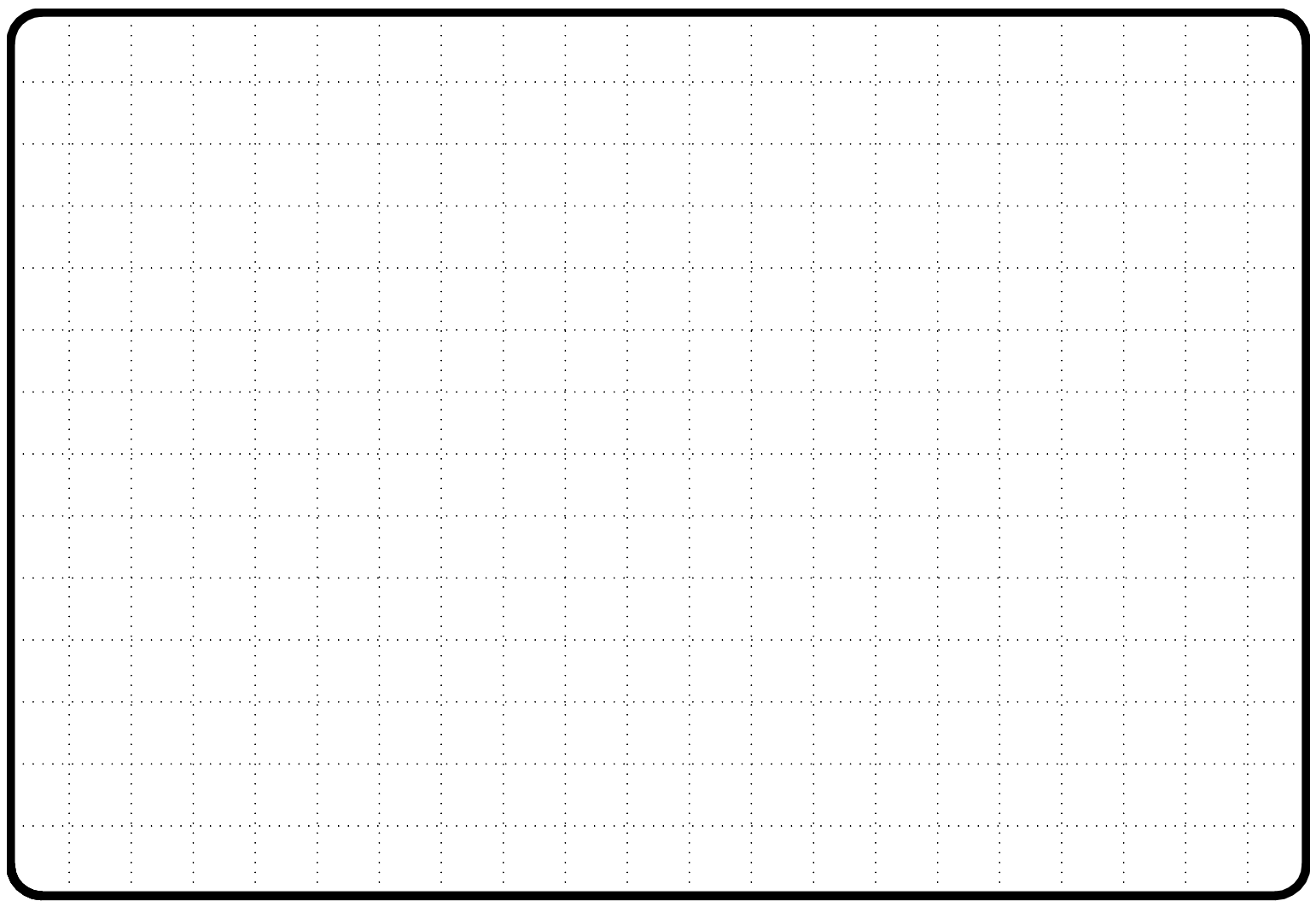

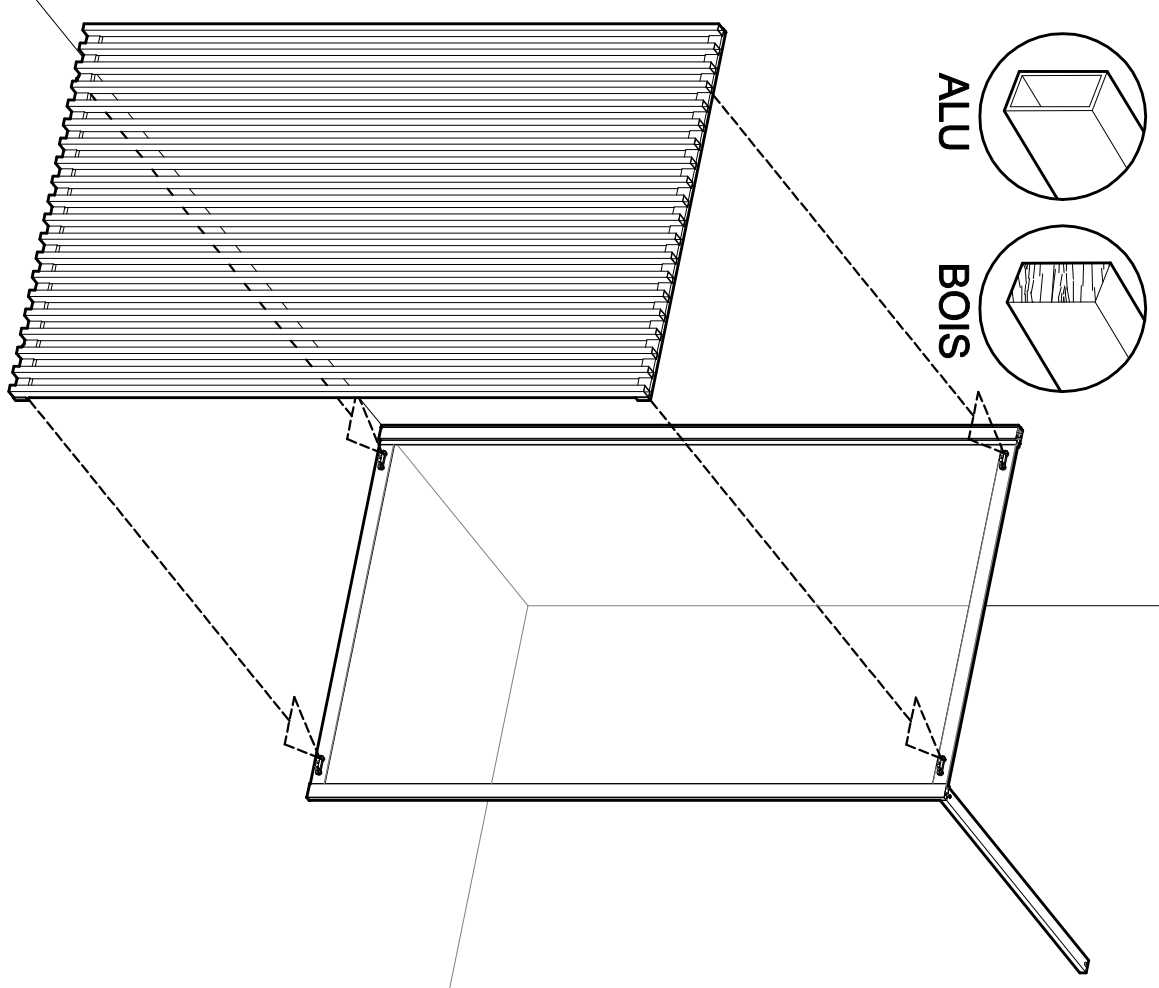
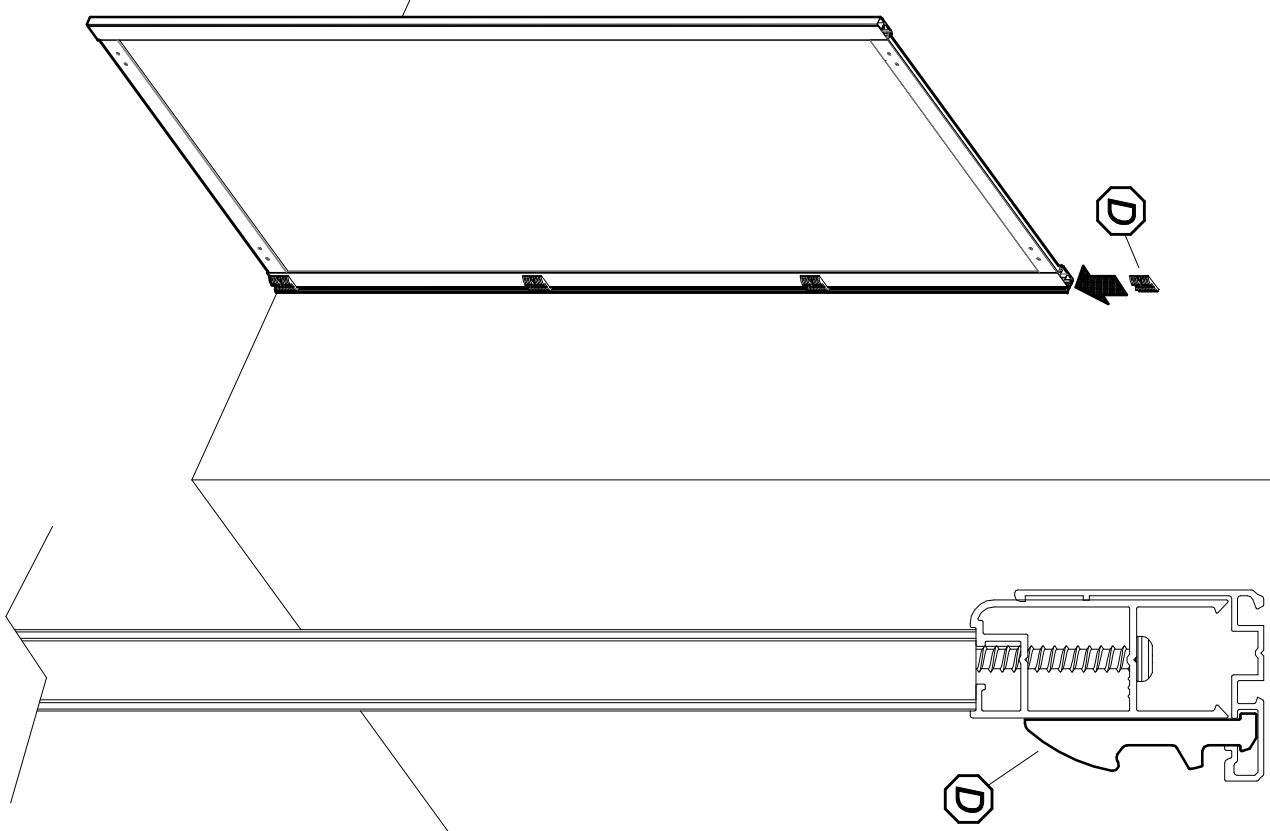

ALU

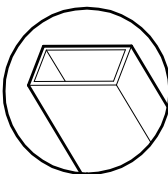

BOIS

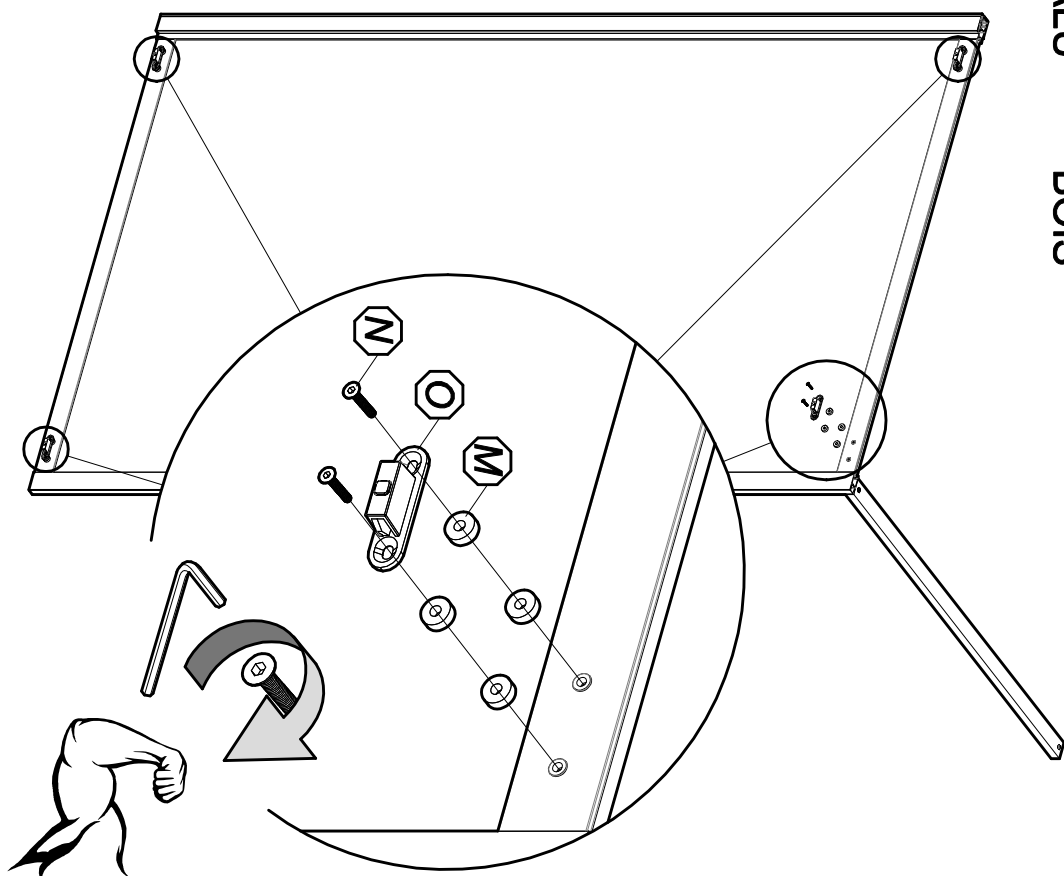
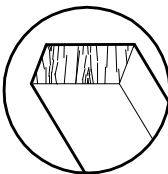

2,5mm.

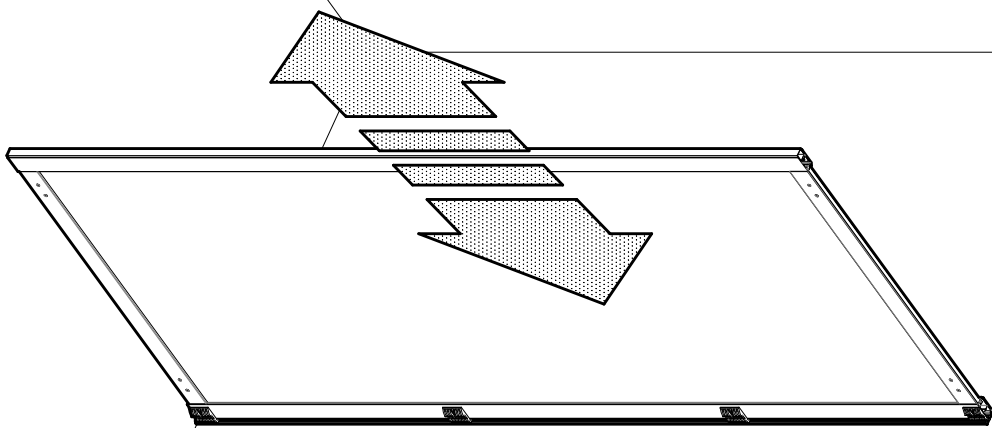

5

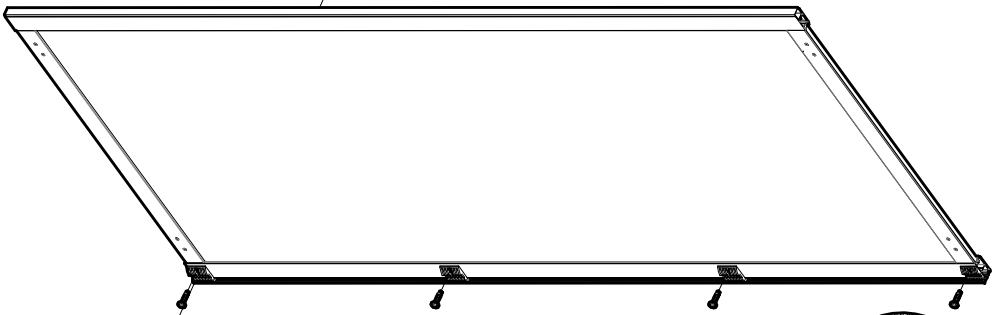
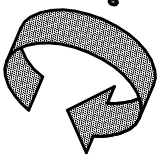
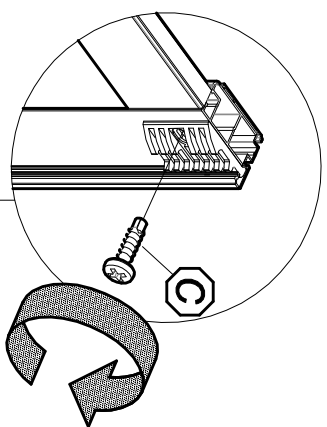

22

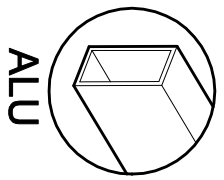

ALU

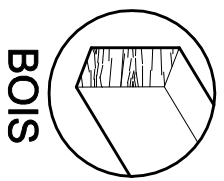

BOIS

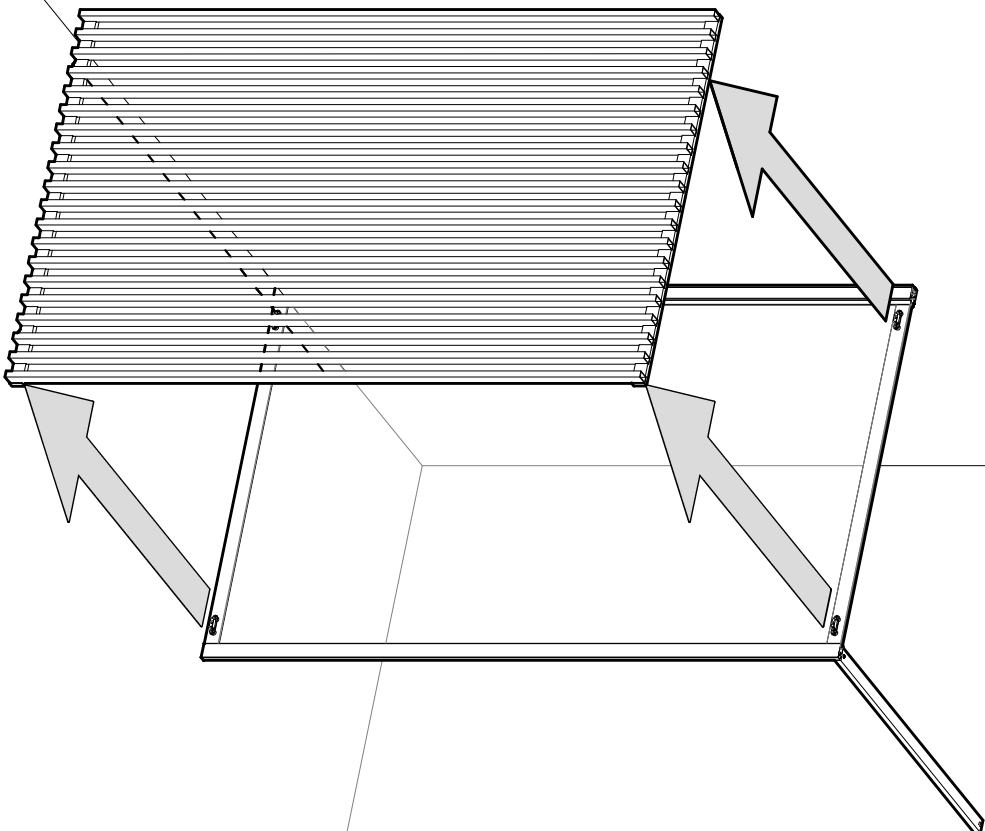

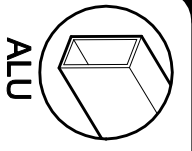

ALU

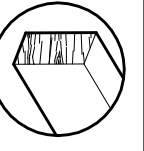

BOIS

21

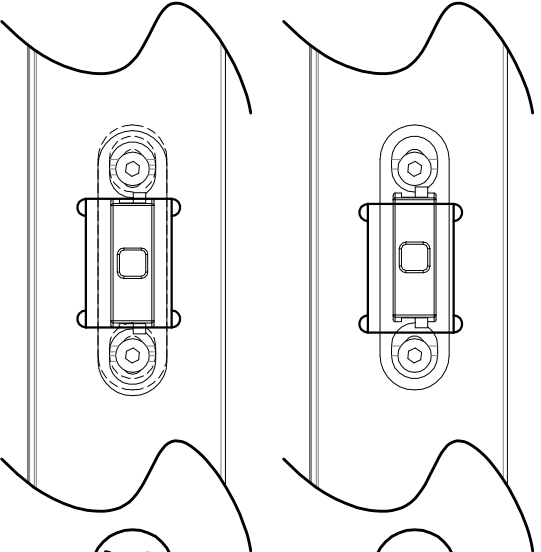
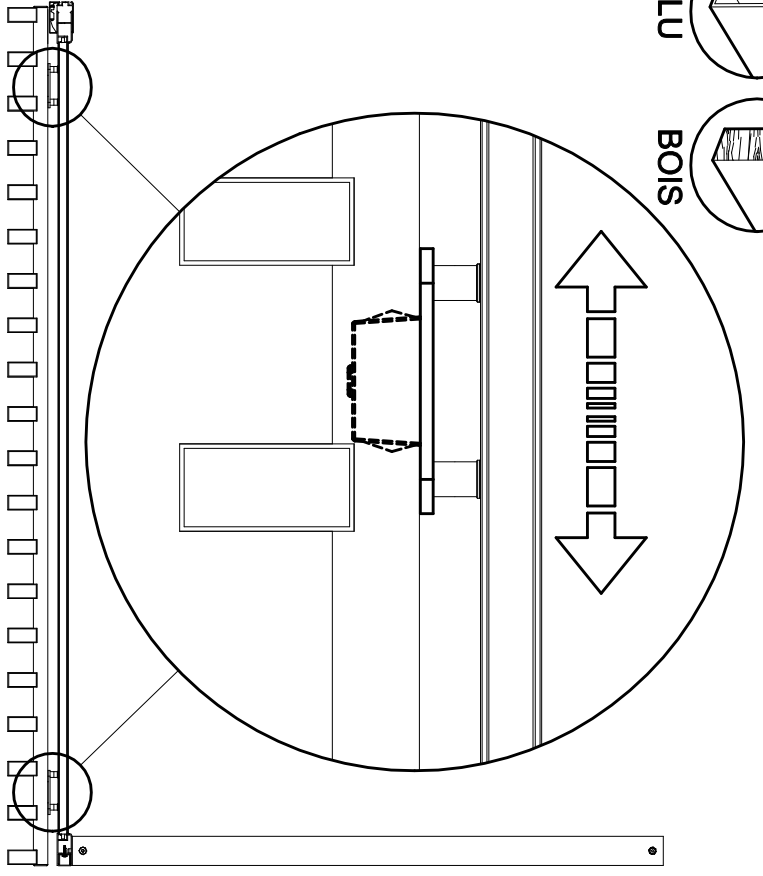

1

X

2

✓

6

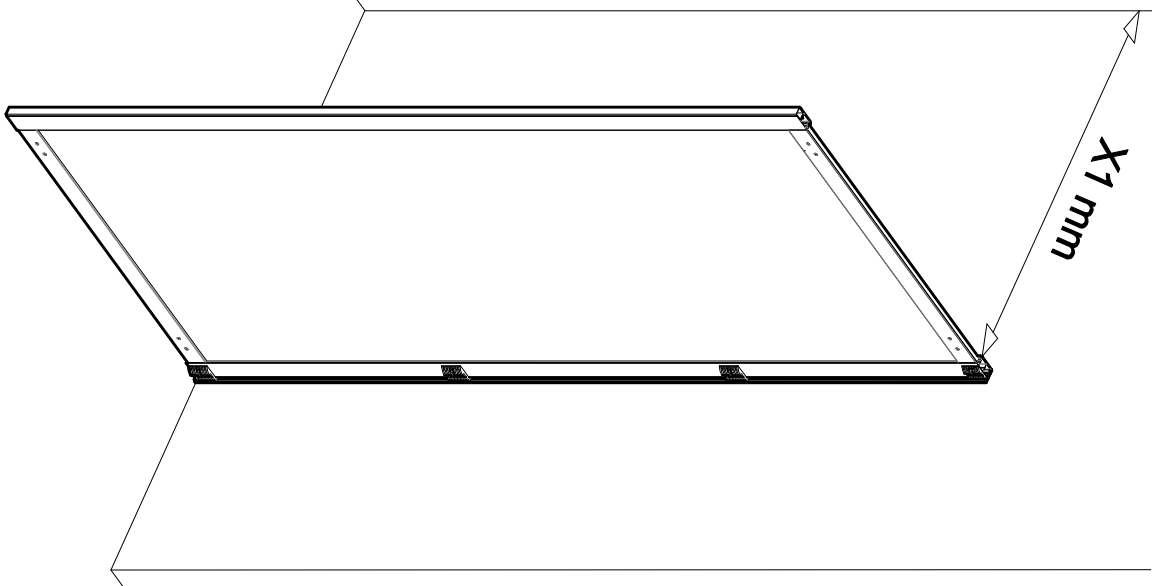

X1 mm

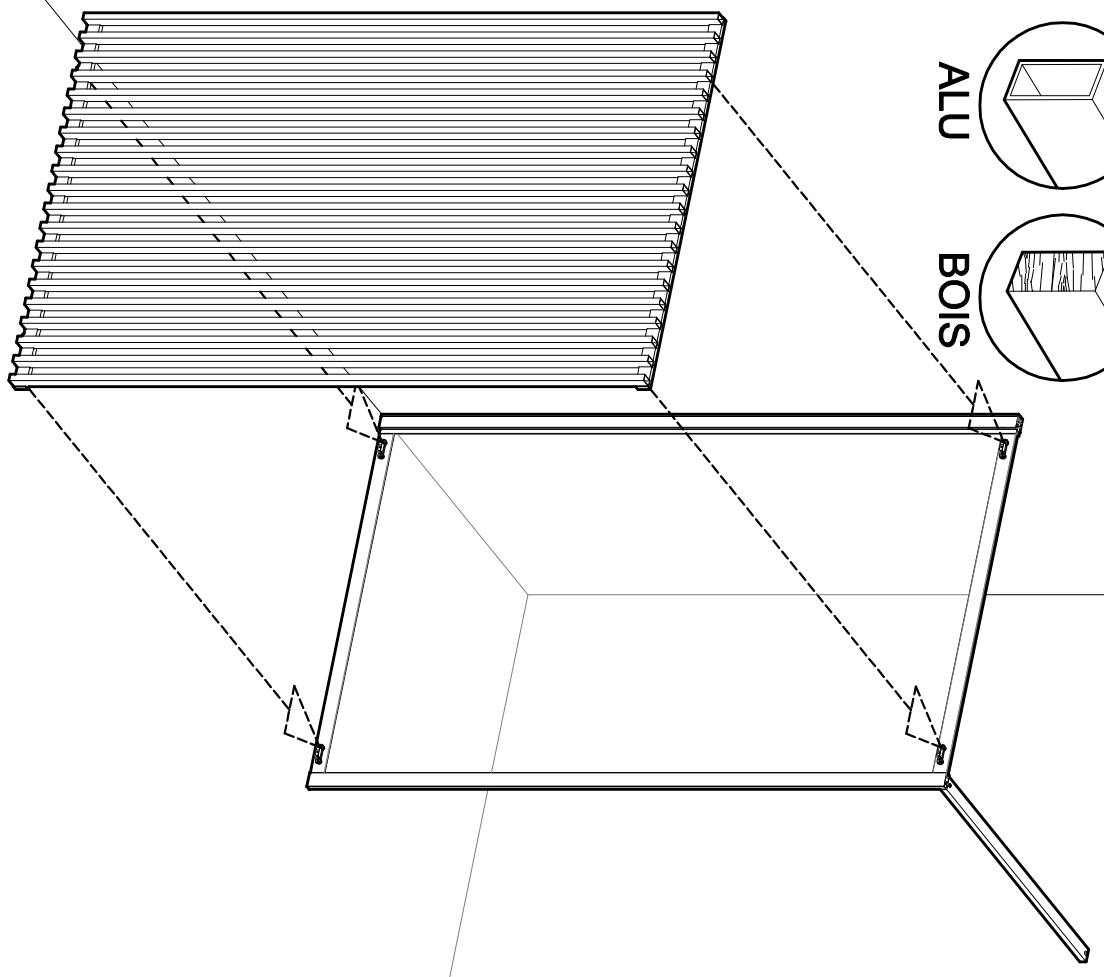
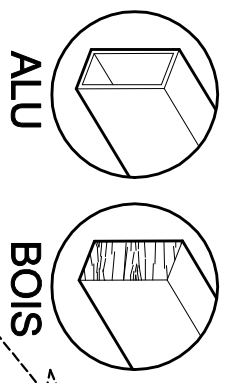
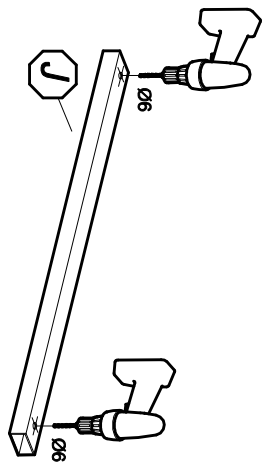
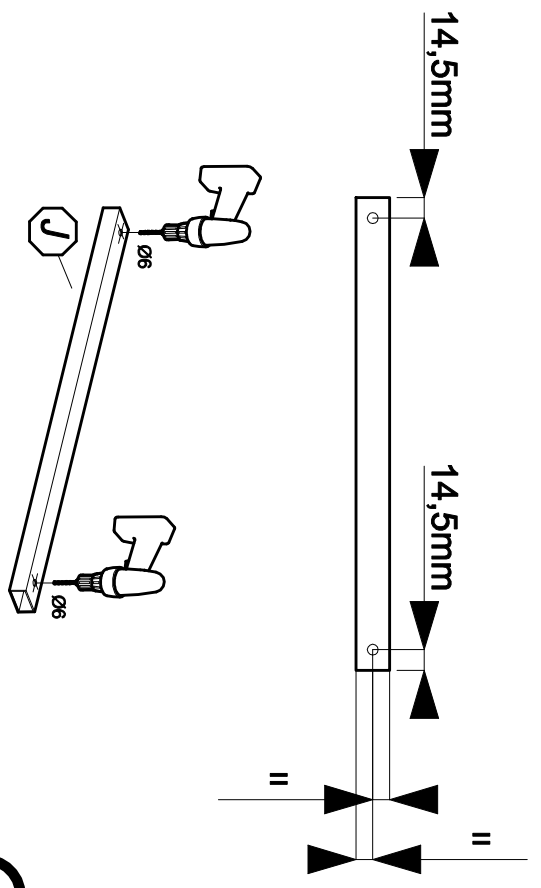
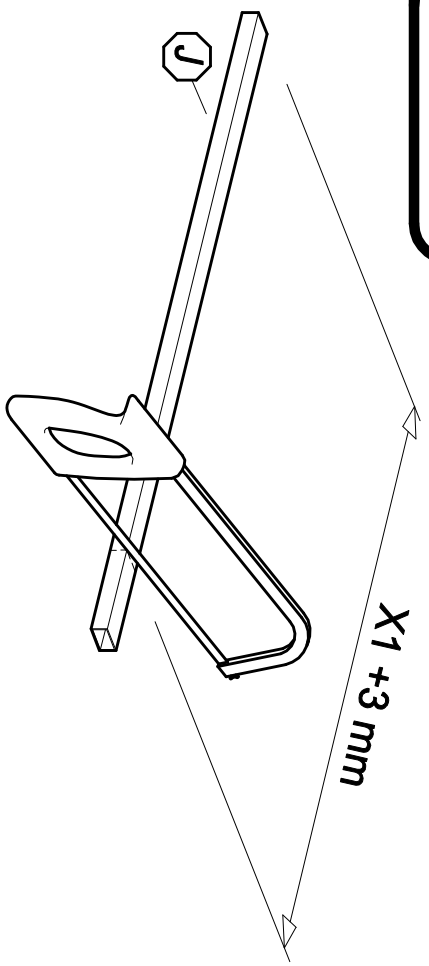
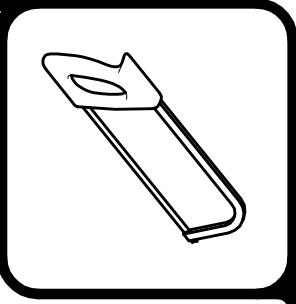

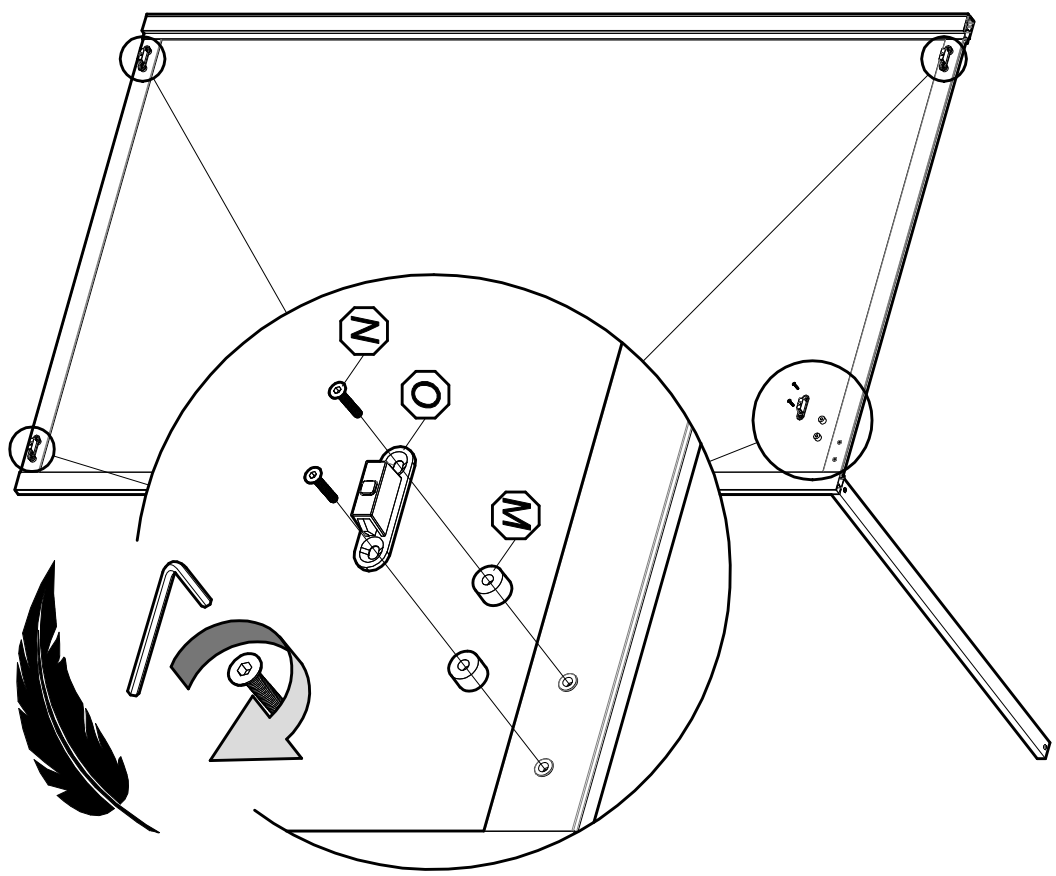

2,5mm.

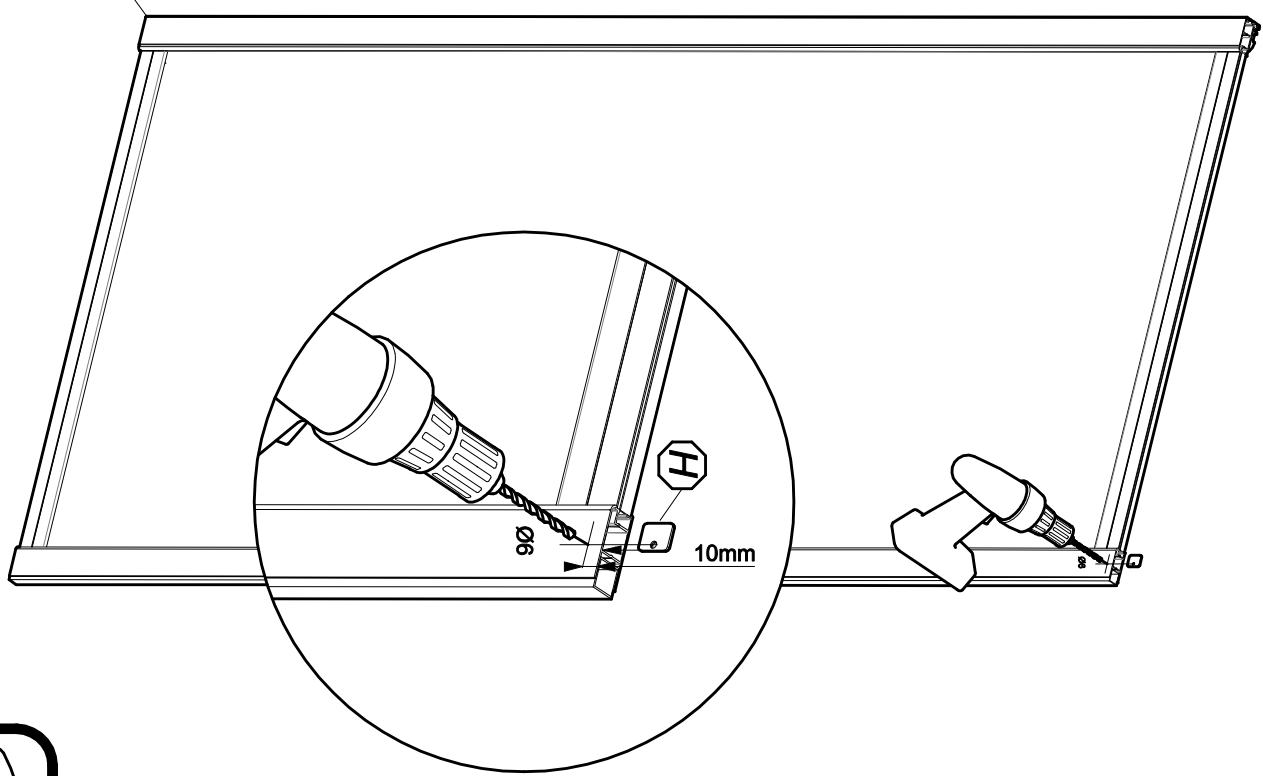

Ø6

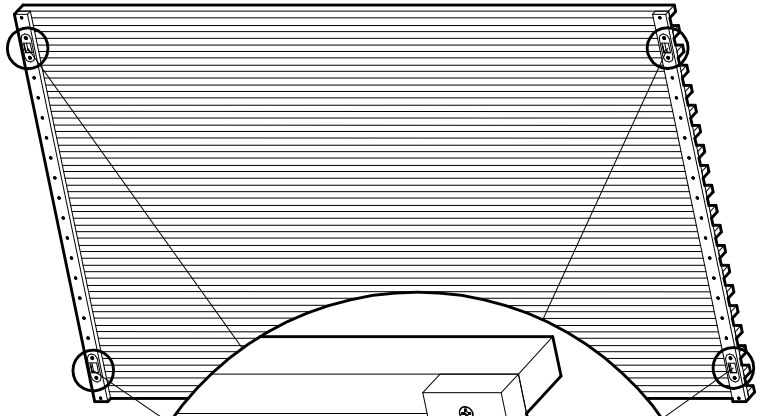
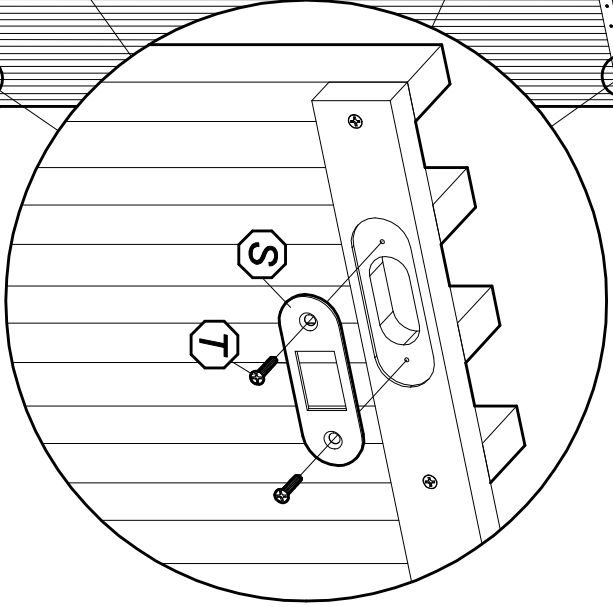
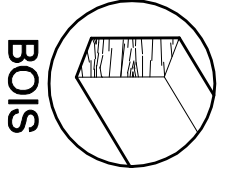
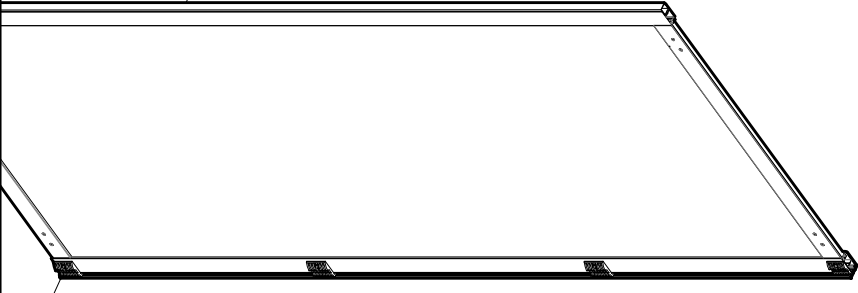
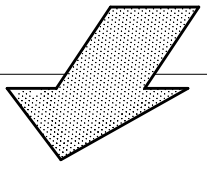
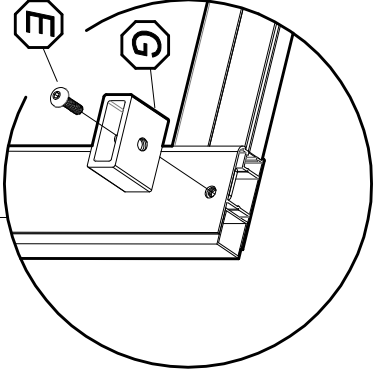
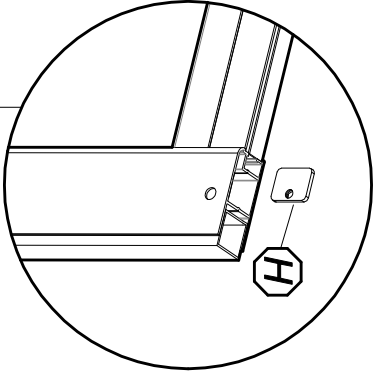

ALU

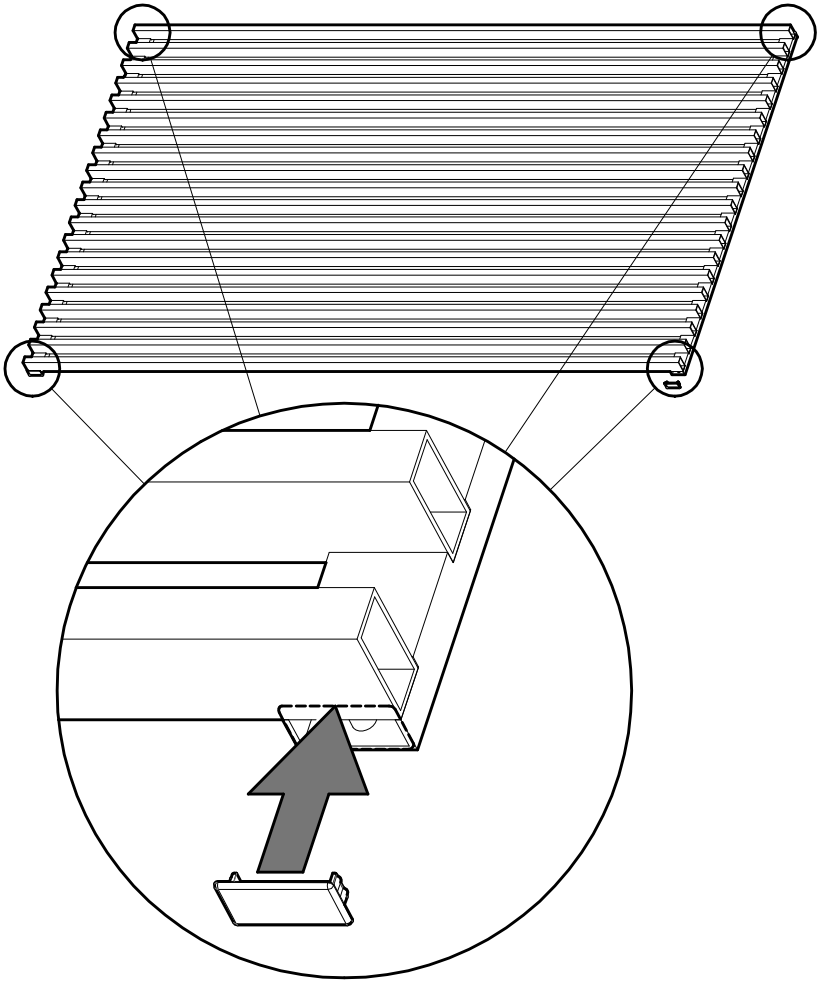
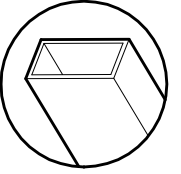

10

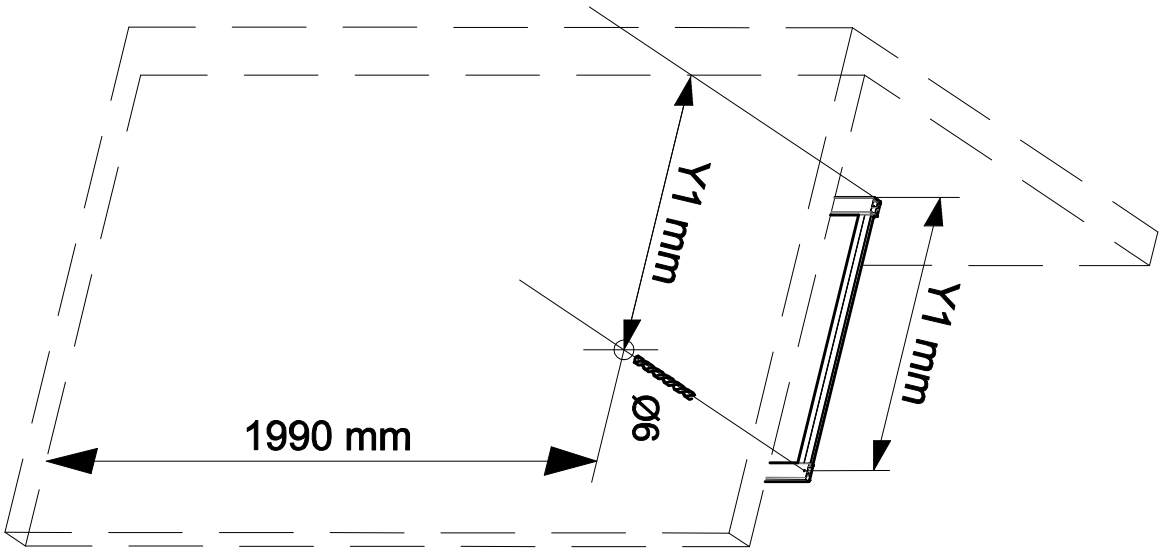

17

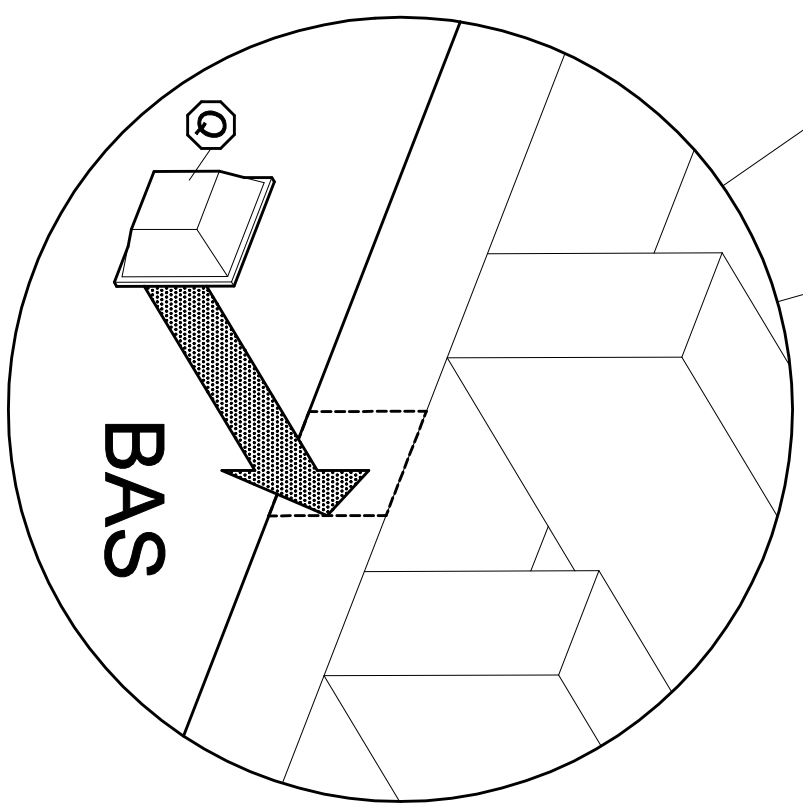
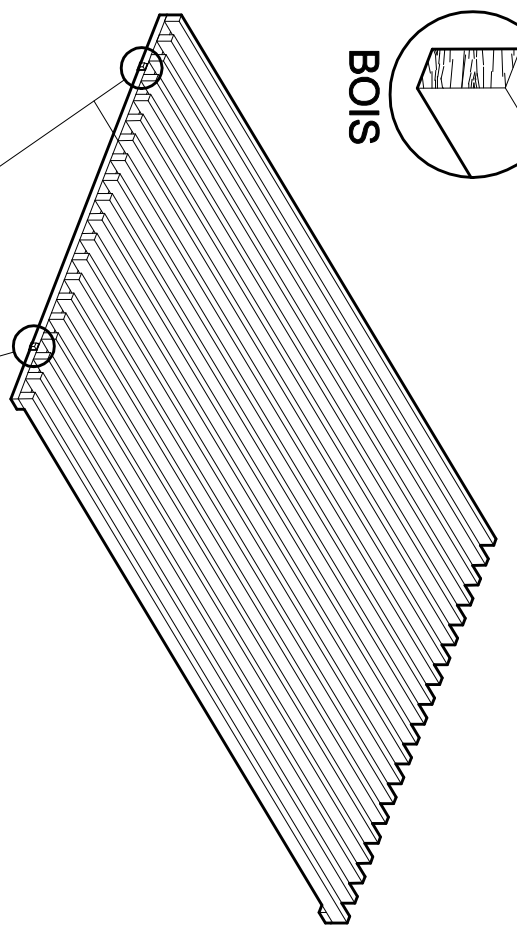
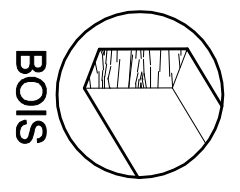
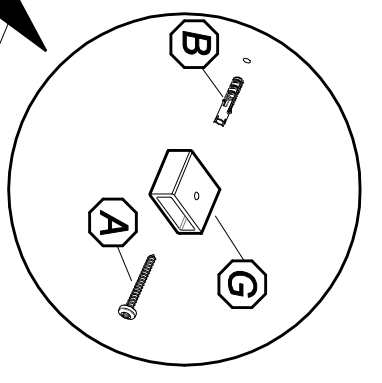
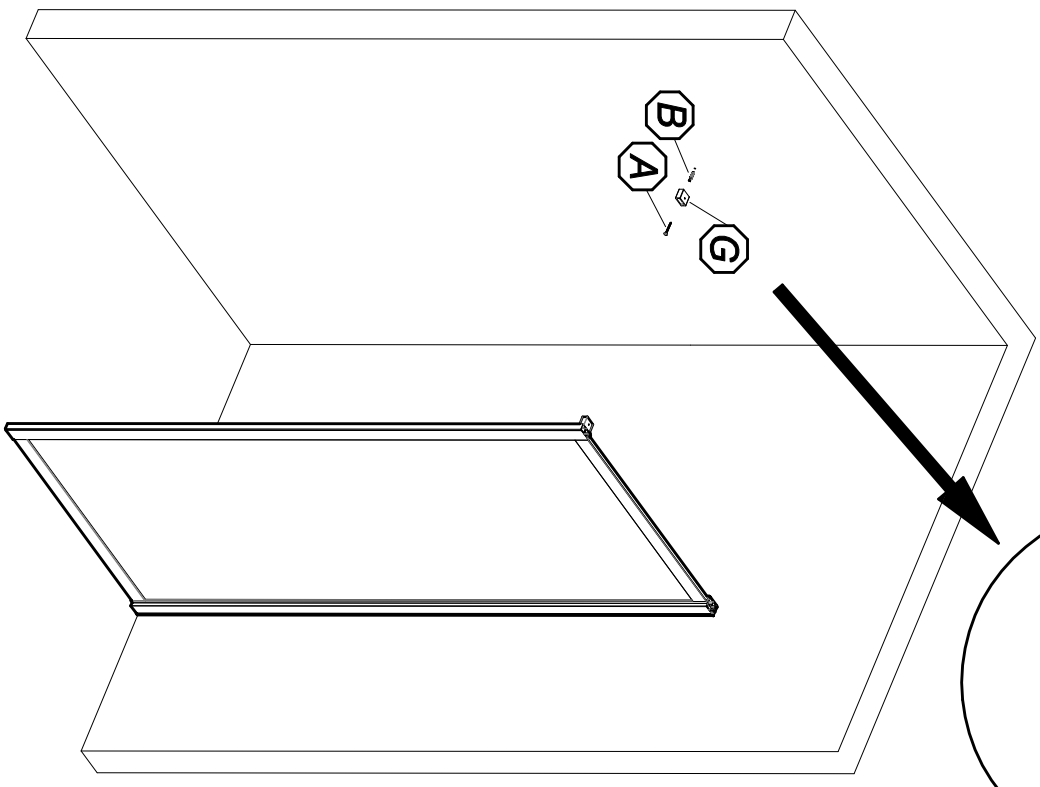

BAS

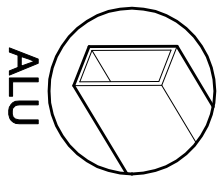

12

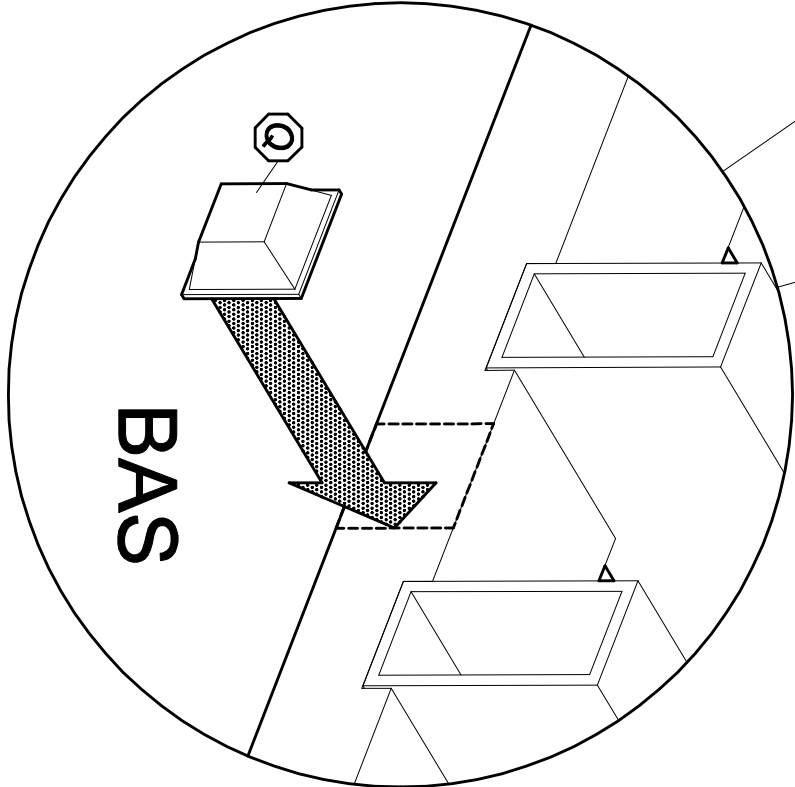
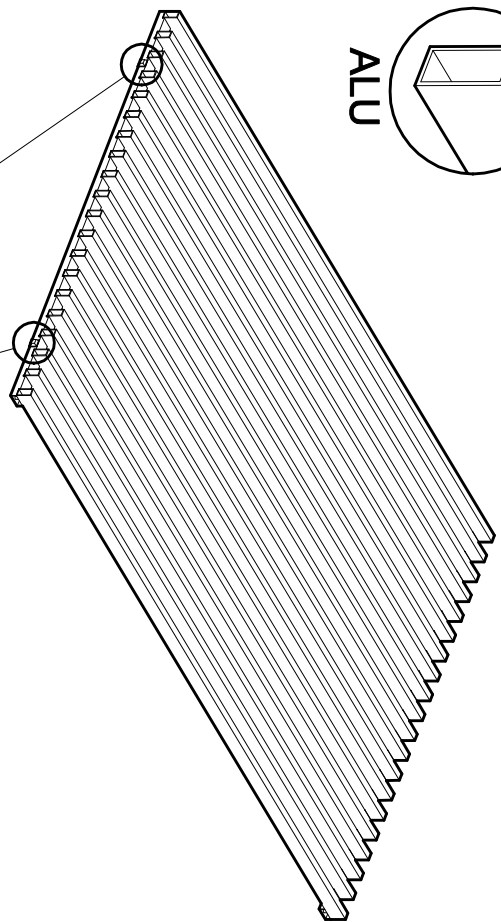

BAS

15

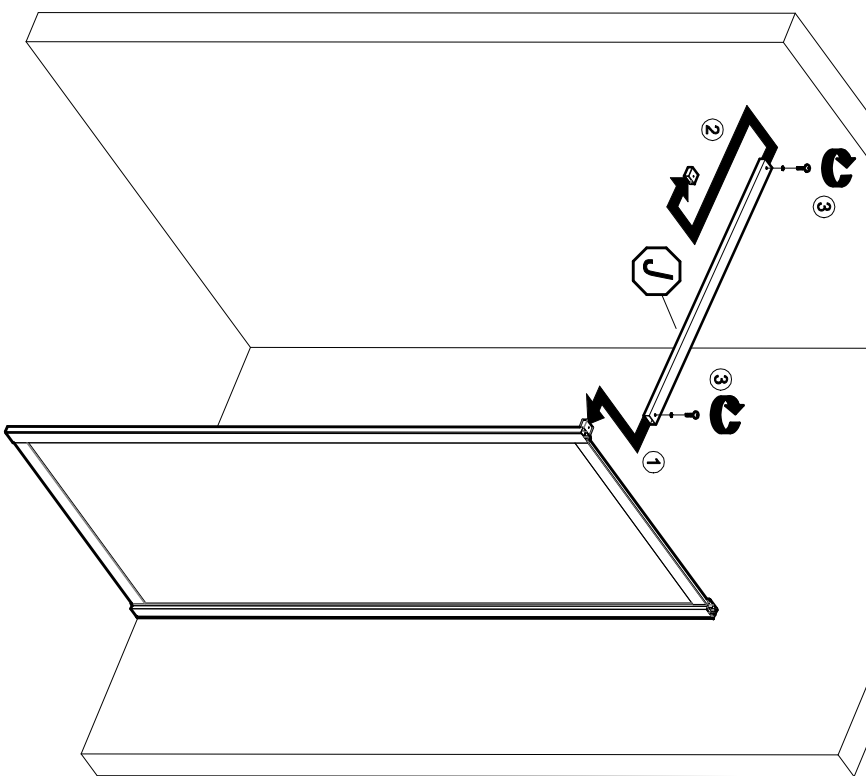
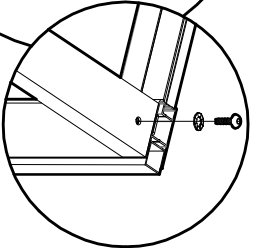
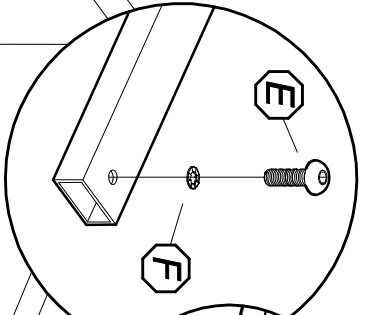

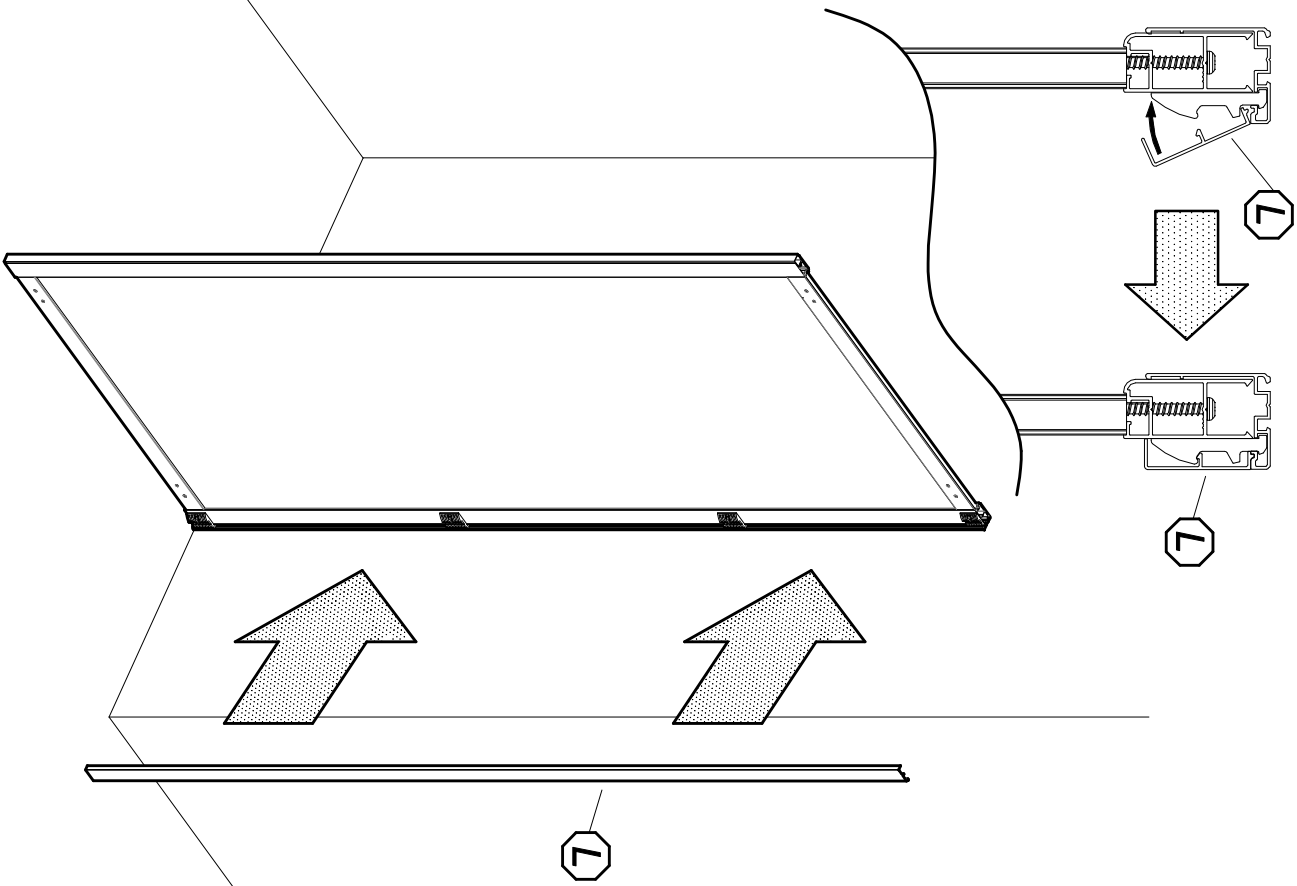

13

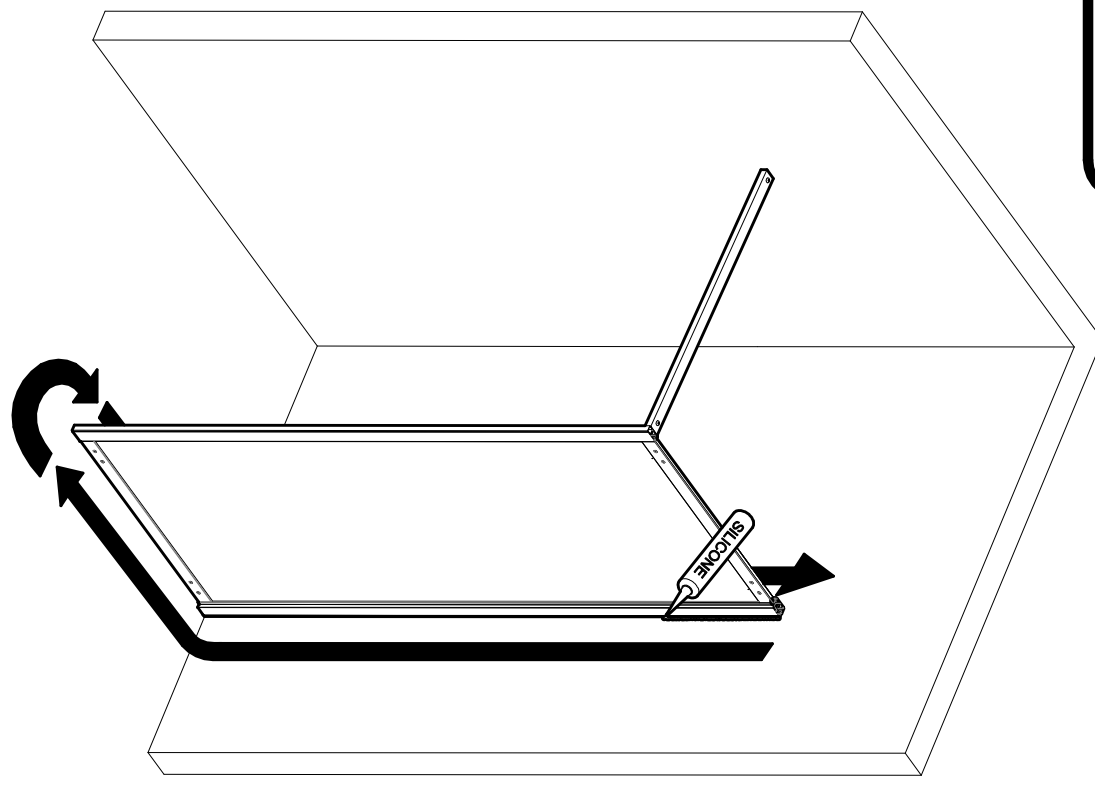

24H.

14

SILICONE